

BOD POD

Body Composition Assessment

The world's gold standard for fast, accurate
and safe body composition assessment

“Numbers you
can trust”



COSMED
The Metabolic Company

The BOD POD® GS-X is the 4th generation of the world's first and only Air Displacement Plethysmograph (ADP) using whole-body densitometry to determine body composition in adults and children...

Since its introduction in 1994, the BOD POD has been used extensively worldwide for a variety of applications within the Healthcare, Academic/Research, Performance, and Wellness sectors. Because the BOD POD's highly accurate ADP technology does not involve radiation, underwater submersion, or difficult testing maneuvers, assessments are quick and simple for both the subject and the operator. This unbeatable combination of accuracy, safety and speed has resulted in the BOD POD now being recognized as the **practical gold standard** for body composition assessment. The BOD POD's ability to test virtually all populations makes it the best and most flexible option for frequent testing and longitudinal tracking of body composition changes over time.

Only the BOD POD offers the unique combination of:

ACCURACY: Scientifically based technology validated in over 2,000 published research articles since 1995

SAFETY: Non-invasive (no radiation) Air Displacement Plethysmography (ADP) technology

SPEED: Quick and easy assessments in less than 5 minutes

CONNECTIVITY: OMNIA™ software for database management, networking, and HL7 integration



Proven Accuracy

Since the publication of the first BOD POD research in 1995, hundreds of additional published research studies have validated the accuracy and reliability of the BOD POD within a diverse range of subjects, including athletes, the elderly, obese, disabled and young children.

Each BOD POD is a complete turnkey system based on the same operating principles as hydrostatic (underwater) weighing, using the principles of whole-body densitometry to determine body composition. This technique relies on a mass measurement from the BOD POD's precise electronic scale and a volume measurement from the BOD POD test chamber.

Once body density ($\text{Density} = \text{Mass}/\text{Volume}$) is determined, the BOD POD measures or predicts Thoracic Gas Volume (TGV) and uses densitometric equations to calculate percent Fat and Fat-Free mass.

Key Features

- **Body Volume, Weight, Fat, and Fat-Free measurements** using whole-body densitometry
- **Non-invasive and safe** for frequent testing
- **Excellent test-to-test reliability**
- **For subjects up to 550 lb and over 7 ft tall**
- **Flexibility in testing special populations**, including young children (with the Pediatric Option™)
- **Faster test time** using the internal electronic volume calibration
- **Direct measurement of Thoracic Gas Volume (TGV)**

BOD POD GS-X

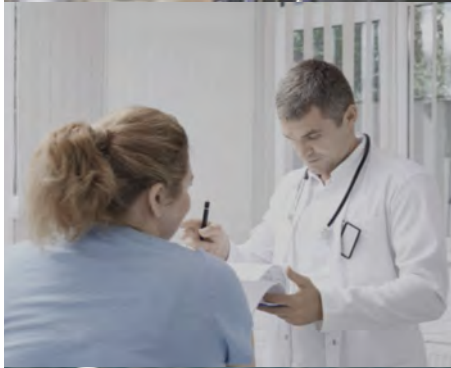

Academia

"Accuracy and flexibility in all populations..."

The BOD POD is ideal for testing a wide range of subjects, including children (as young as 2-years of age with the Pediatric Option™ accessory), the elderly, obese, and disabled. It is also the best choice for frequent, repeat testing, and is used in a variety of university research and teaching departments. There is no need for cross-calibration in multi-center studies due to the BOD POD's proven intra-device reliability. The BOD POD is used throughout academic departments, including:

- **Exercise Science**
- **Kinesiology**
- **Nutrition**

Healthcare

"Measure what you manage..."

A BOD POD assessment contains the key data necessary for developing personalized health plans to lower disease risk and provides essential feedback regarding nutritional intervention. The BOD POD is widely used in:

- **Clinical Nutrition**
- **Obesity Medicine**
- **Medical Research**, including diabetes, cardiovascular, and cancer

Performance

"Train like a champion..."

The BOD POD is a powerful tool for monitoring and tracking the effectiveness of training and nutrition programs, making it a critical component for optimizing physical performance. The large BOD POD test chamber allows for the testing of subjects over 7 ft tall and is used extensively in:

- **Professional Sports**, including top NFL teams and the NFL Combine since 2006
- **College & University Athletics**
- **Military**, including Special Forces, Army Wellness Centers (AWC), and Air Force Health & Wellness Centers (HAWC) worldwide
- **Public Safety**

Wellness

"Paving the path to healthy habits..."

The insight offered from a BOD POD assessment provides valuable input for implementing lifestyle changes to improve fitness and well-being. The BOD POD is routinely used for promoting a healthy balance of fat and muscle in:

- **Weight Loss Clinics**
- **Health Clubs**
- **Resorts & Spas**

System Components

Each BOD POD system comes complete with all necessary components, including:

- BOD POD Chamber (>500 liters)
- Electronic Scale and Calibration Weights
- Integrated 24-inch Touch-Screen Workstation with operational capability and option to add COSMED cardiopulmonary equipment with gas tanks*
- OMNIA Data Management Software

**In North American markets only*



Test Process

Testing with the BOD POD is extremely fast and easy. There are no operator licenses necessary or complex subject maneuvers required. The BOD POD's efficient electronic internal volume calibration and user-friendly TGV routine/system allow for a complete test to be accomplished in less than 5 minutes using the following steps:

- (1) Basic subject information is entered into the BOD POD software program
- (2) The subject's mass is measured using the electronic scale (accuracy is verified by regular calibrations using the provided calibration weights)
- (3) The subject's body volume is measured while sitting inside the BOD POD for 2 minutes
- (4) Thoracic Gas Volume (TGV) is measured or a predicted equation is used
- (5) Test results are displayed and printed



Improved subject compliance with new TGV measurement procedure, including the ability to perform and average multiple trials.

Software

- Population density models included for Children, Adults, Pregnant Women, and Ethnic Groups
- Ability to enter data (Total Body Water, Mineral, Protein) for other compartments in 3 and 4-Compartment Models
- Data export capability

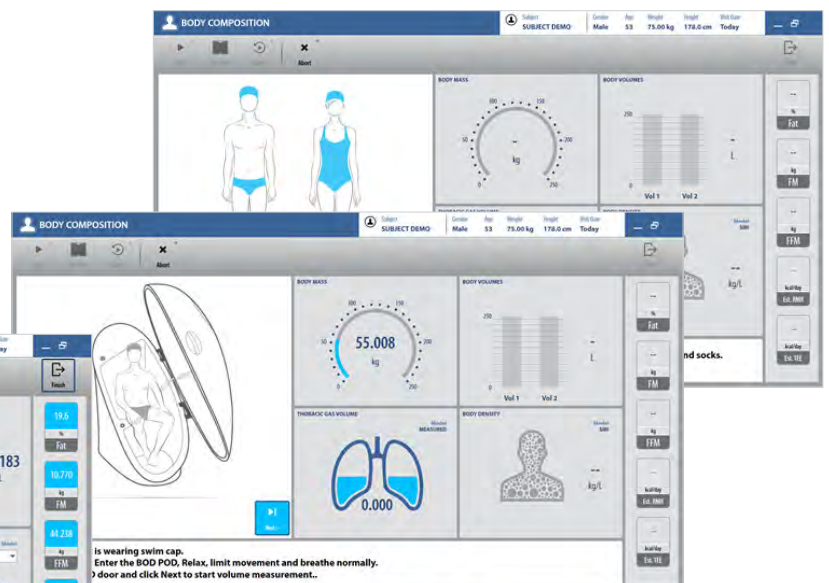
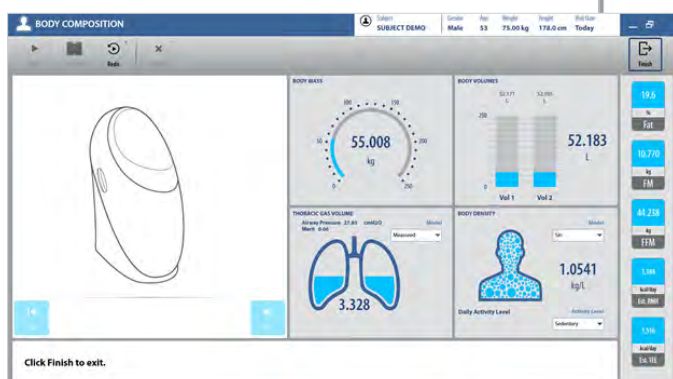

Intuitive and user-friendly software interface

Test Results & Printouts

- Results are presented in software and printouts in graphical and tabular format
- Detailed color printouts are designed for intuitive results interpretation
- Research-based body composition references are provided for adults, elderly (up to 90 years old), and athletes (by sport and position)
- References are provided as Mean \pm 1, 2, 3 SD, providing valuable information on results distribution
- Ability to edit and print software-generated automatic interpretation
- Ability to enter compartmental information (total Body Water, Mineral, Protein), allowing for the calculation of body composition using 3- or 4-compartment models



Highlights:

- Software and printed results are supported by research-based body composition references
- Over 60 sport and position-specific references offered
- Data entry capability for the use of 3- and 4-compartment models

Only the BOD POD® GS-X offers the mobility and flexibility for easily and comfortably testing nearly all populations, ranging from young children to elderly adults...



Data Management

The Body Composition module of COSMED's OMNIA software (included) provides calibration checks, visual test sequence, and easy reporting with import/export capabilities, PHI and HIPAA compliant.

OMNIA Networking Software (Option)

The OMNIA Networking software (sold separately) allows for the sharing of a single database for integration of BOD POD test data with all COSMED systems and connected devices (ECG, CO, BPM, SmO₂, SpO₂, etc.) on Standalone, Local, and Wide Area Networks (WANs).

OMNIA HL7 Software (Option)

The OMNIA HL7 software (sold separately) permits secure receipt of data requests from HL7 worklists for sending results to Electronic Medical Records (EMR) and Hospital Information Systems (HIS).

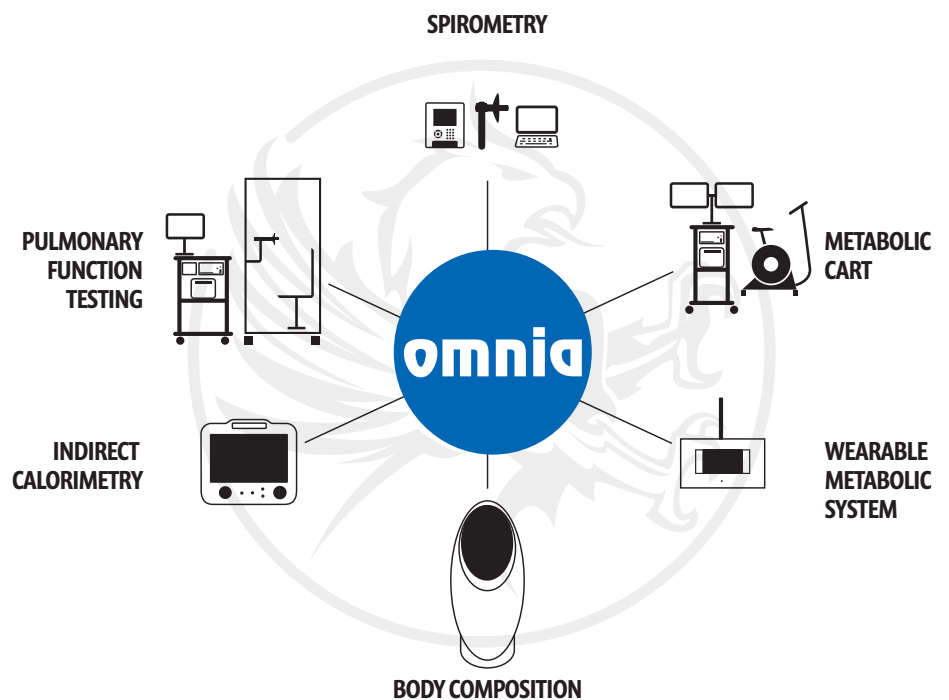

Pediatric Option™ Accessory

The BOD POD with the Pediatric Option accessory (sold separately) allows for the body composition assessment of children between 2 and 6 years old, and as small as 12kg⁽¹⁾. It includes a customized seat insert to create a safe and comfortable testing environment, calibration standard, and modified software for testing young children.

⁽¹⁾FIELDSDA, et al. Air-displacement plethysmography pediatric option in 2-6 year olds using the four-compartment model as a criterion method. *Obesity*, 20(8):1732-1737 (2012)



The Pediatric Option accessory allows for easy body composition assessment of young children

Maintenance

The BOD POD is designed for durability over time. Should the need arise, each BOD POD has an internal diagnostic function for analyzing system performance and providing feedback to service personnel. Extended service agreements are also available to insure optimal performance for long term use.



About COSMED

COSMED is the manufacturer of premier Cardio Pulmonary, Metabolic and Body Composition diagnostic equipment. The Company was founded in 1980, with global headquarters in Rome, Italy, and US headquarters in Concord, California. Since its inception, COSMED's primary goal has been to continually improve the quality of its technologies and products through innovation and superior customer service.



COSMED
The Metabolic Company

Research Articles (Partial Listing)

Review & Validation

- **FIELDS DA, et al.** Air displacement plethysmography: Cradle to grave. *Nutr Clin Pract*, 30(2):219-226 (2015)
- **BALL SD, et al.** Interdevice variability in percent fat estimates using the BOD POD. *Eur J Clin Nutr*, 59(9):996-1001 (2005)
- **FIELDS DA, et al.** Body-composition assessment via air-displacement plethysmography in adults and children: A review. *Am J Clin Nutr*, 75(3):453-467 (2002)
- **MCCRORY MA, et al.** Evaluation of a new air displacement plethysmograph for measuring human body composition. *Med Sci Sport Exerc*, 27(12):1686-1691 (1995)

Obesity

- **WINGFIELD HL, et al.** Body composition assessment in overweight women: Validation of air displacement plethysmography. *Clin Physiol Funct Imaging*, 34(1):72-76 (2014)
- **GINDE SR, et al.** ADP: Validation in overweight and obese subjects. *Obes Res*, 13(7):1232-1237 (2005)

Pregnancy

- **MOST J, et al.** Advances in assessing body composition during pregnancy. *Eur J Clin Nutr*, 72:645-656 (2018)
- **FORSUM E, et al.** The two-component model for calculating total body fat from body density: An evaluation in healthy women before, during and after pregnancy. *Nutrients*, 6(12):5888-5899 (2014)

Children

- **NYSTRÖM CD, et al.** The paediatric option for BodPod to assess body composition in preschool children: What fat-free mass density values should be used? *Br J Nutr*, 120(7):797-802 (2018)
- **FIELDS DA, et al.** Air-displacement plethysmography pediatric option in 2-6 years old using the four-compartment model as a criterion method. *Obesity*, 20(8):1732-1737 (2012)
- **FIELDS DA, et al.** Body composition techniques and the four-compartment model in children. *J Appl Physiol*, 89:613-620 (2000)

Elderly

- **ALEMÁN-MATEO H, et al.** Body composition by the four-compartment model: validity of the BOD POD for assessing body fat in Mexican elderly. *Eur J Clin Nutr*, 61:830-836 (2007)

Athletics

- **FIELDS JB, et al.** Body composition variables by sport and sport-position in elite collegiate athletes. *J Strength Cond Res*, 32(11): 3153-3159 (2018)
- **TUCKER AM, et al.** Prevalence of cardiovascular disease risk factors among National Football League players. *JAMA*, 301(20):2111-2119 (2009)

Military

- **RIVERA LO, et al.** Building efficiency and quality in health education: The Army Wellness Center model. *ACSM's Health & Fitness Journal*, March/April 20(2):19-23 (2016)

Technical Specifications

Product	Description	REF
BOD POD GS-X	BOD POD GS-X Body Composition Tracking System	A-661-230-040
Standard Packaging	BOD POD unit; Power Supply, Transformer Assembly (includes Power Cord and Power Cables for BOD POD Power Supply, All-in-One Touchscreen Computer/Monitor, Printer), Calibration Weights (2 pcs), Electronic Scale, BOD POD Workstation (Cart), All-in-One Touchscreen Computer/Monitor, USB Cable, Printer, Printer Cable, OMNIA Software, OMNIA USB Dongle, Breathing Tube and Filter Kits (50 pcs), Nose Clip, Window Cleaner, Window Cleaning Cloths (5 pcs), Swim Cap, Operator's Manual	
Measurements		
Body Composition	Body Weight, Body Volume, Body Density, Fat Mass (lb/kg and %), Fat-Free Mass (lb/kg and %), Thoracic Gas Volume (TGV), Resting Metabolic Rate (estimated), Total Energy Expenditure (estimated)	
Accuracy	Measurements have been found to be equivalent (no statistically significant difference) to those obtained using 4-Compartment Model and Underwater Weighing (UWW) reference techniques	
Mass Measurement (with High Precision Digital Scale)		
Dimensions & Weight (Scale)	14.0 x 16.0 x 3.5 in (35.6 x 40.6 x 8.9 cm) / 24 lb (10.9 kg)	
Weight Range	Up to 550 lb (250 kg)	
Accuracy	0.05%	
Calibration	20 kg Weights	
Volume Measurement		
Dimensions & Weight (POD)	66 x 33 x 53 in (167 x 84 x 135 cm) / 550 lb (250 kg)	
Chamber Volume	500 L	
Accuracy	±100 ml of Cylinder Volume	
Calibration	Automatic (Electronic Internal)	
Environmental Conditions		
Temperature	Between 70°F/21°C and 80°F/27°C (Operating); 40°F/5°C and 100°F/38°C (Storage)	
Humidity	20-70% (Non-Condensing)	
Barometric Pressure	75-106 KPa (562-795 mm Hg)	
Hardware		
Power Requirements	100-240V ±10% 50/60 Hz	
Software		
Available Languages	English	
PC Configuration (All-in-One PC included)	Windows® 10 (64-bit) Minimum Requirements: Windows 7, 8, 10	
Accessories & Options		
Pediatric Option	For subjects between 2 and 6 years old (and as small as 12 kg)	A-661-230-042
Safety & Quality Standards		
MDR 2017/745; FDA 510(k); EN 60601-1 (Safety) / EN 60601-1-2 (EMC)		

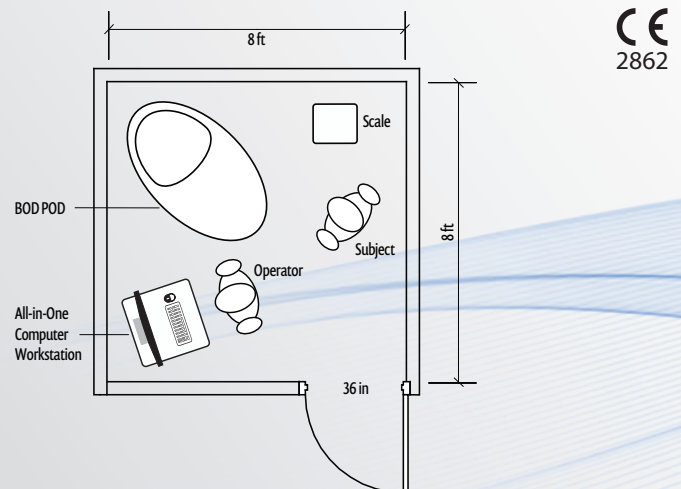

BOD POD and PEA POD are manufactured in California by COSMED USA

COSMED USA, Inc.

1850 Bates Avenue
Concord, CA USA 94520

+1 (800) 426-3763 Toll Free
+1 (925) 676-6002 Phone
+1 (925) 676-6005 Fax

us@cosmed.com | cosmed.com

COSMED Srl

Via dei Piani di Monte Savello 37
Albano Laziale - Rome 00041, Italy

+39 (06) 931-5492 Phone
+39 (06) 931-4580 Fax

For more info:

